

STRESS ANALYSIS OF ANNULAR SANDWICH PLATES OF LINEARLY VARYING THICKNESS

N. PAYDAR

Department of Mechanical Engineering, School of Engineering and Technology,
Purdue University, Indianapolis, IN 46223, U.S.A.

(Received 8 October 1986; in revised form 19 August 1987)

Abstract—A small deflection theory is presented for stresses and deformations in variable thickness elastic annular sandwich plates that are symmetric about a middle surface. Both the energy expression and the differential equations are developed. In this analysis, the face sheets are treated as membranes, the core is assumed to be inextensible in the thickness direction, to carry only transverse shear stress on its cross sections normal to middle surface, and to be deformable in transverse shear. The theory takes into account the contribution of the face sheet membrane forces (by virtue of their slopes) to the transverse shear.

1. INTRODUCTION

In stress analyzing homogeneous plates of variable thickness, it is generally accepted[1] that one may continue to use the constant-thickness moment-curvature relations, provided that at each location, one employs the local values of the plate stiffnesses based on the local thickness. When dealing with sandwich plates of variable thickness, there has been a natural inclination[2] to take a similar approach; that is, to use the constitutive equations of constant-thickness sandwich plate theory[3], but allowing the transverse shear stiffness, the flexural stiffnesses, and the twisting stiffness to vary with the plate coordinates in accordance with the local thickness. This approach neglects two factors: (a) the transverse shear components of the membrane stresses in the face sheets, which alter the transverse shear carried by the core and, therefore, the transverse shear deformation; (b) the face sheet membrane strains arising from transverse shear deformation of the core. References [4, 5] showed that neglect of these factors in stress analysis of rectangular sandwich plates of variable thickness can lead to significant errors, especially when the core has a low transverse shear modulus and is highly tapered.

Stress analysis of annular sandwich plates of linearly varying thickness is considered in what follows here. The plate is assumed to be symmetric about a middle surface, and the face sheets are assumed to be very thin compared to the core, so that they can be treated as membranes. The core is assumed to be inextensible in the thickness direction, to carry only transverse shear stress on its vertical cross sections, and to be deformable in transverse shear. The thickness of the core and that of both face sheets are taken to be h and t , respectively. Both faces are of the same material, different from that of the core. Loading on the plate consists of a running vertical load q as a function of r per unit of middle surface area, resulting in an axisymmetric annular plate.

2. DISPLACEMENTS AND STRAINS

Upon the application of the load, the assumedly inextensible line element AB (shown in Fig. 1) can experience the following movements which are assumed to be small: (1) transverse displacement w ; (2) rotation θ about its midpoint, in the vertical plane parallel to the r -axis. These movements impart to point A the displacement u , along the upper face sheet as

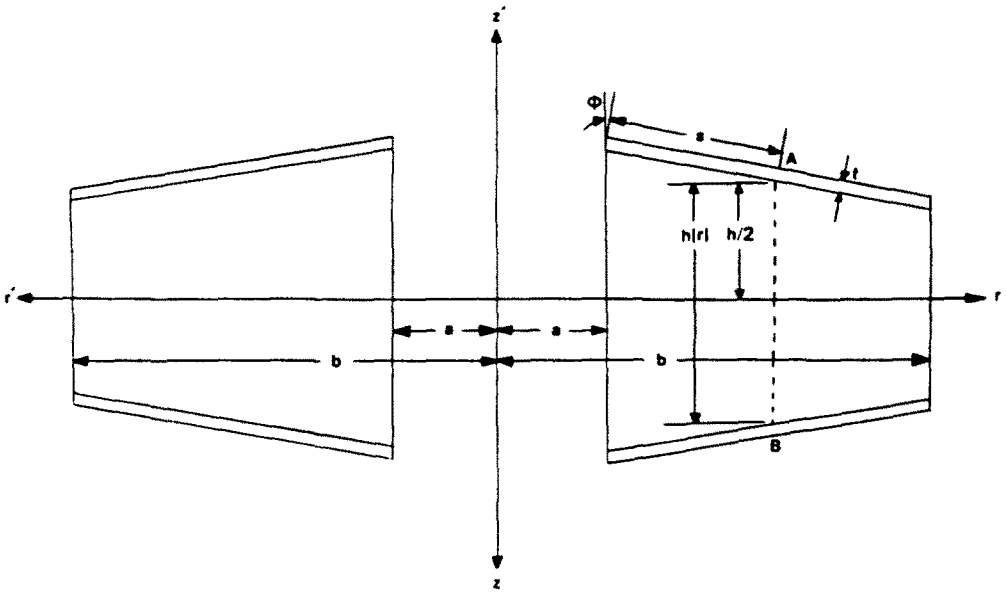

Fig. 1. Annular sandwich plate of linearly varying thickness.

$$u_r = \frac{h}{2} \theta \cos \phi + w \sin \phi. \tag{1}$$

This displacement gives rise to the strain

$$\epsilon_r = \frac{\partial u_r}{\partial r} = \frac{h}{2} \cos^2 \phi \frac{d\theta}{dr} + \frac{1}{2} \sin 2\phi \left(\frac{dw}{dr} - \theta \right) \tag{2}$$

in the upper face sheet. The corresponding strain in the lower face sheet is $-\epsilon_r$. The upper face sheet circumferential strain is given by

$$\epsilon_c = \frac{h}{2} \frac{\theta}{r}. \tag{3}$$

Also w and θ give rise to the following transverse shear strain γ_{rz} in the core:

$$\gamma_{rz} = \frac{dw}{dr} - \theta. \tag{4}$$

3. STRESSES AND STRESS RESULTANTS

In this analysis, the face sheets and the core are assumed to be isotropic, and the following stress-strain relations are used.

For the face sheets

$$\sigma_r = E^*(\epsilon_r + \nu \epsilon_c), \quad \sigma_c = E^*(\epsilon_c + \nu \epsilon_r). \tag{5}$$

For the core

$$\tau_{rz} = G\gamma_{rz} \tag{6}$$

where $E^* = E/(1 - \nu^2)$, E and ν are the modulus of elasticity and Poisson's ratio of the face sheets, respectively, and G is the core shear modulus of elasticity.

The stress resultants Q and M_r are defined as the transverse shear and radial bending moment per unit circumferential width, while M_c is the circumferential bending moment per unit radial width of the middle surface. These stress resultants are related to the stresses carried by the core and the face sheets by the following relations:

$$\begin{aligned} Q &= Q_{\text{core}} + 2\sigma_t \sin \phi \\ M_r &= -\sigma_t h \cos \phi \\ M_c &= -\sigma_c t h \sec \phi \end{aligned} \quad (7)$$

where $Q_{\text{core}} = \tau_{rz} h$ is the shear carried by the core per unit width.

Substituting eqns (2)–(4) into eqns (5) and (6), then substituting the resulting equations into eqns (7), and upon nondimensionalization, we obtain the following dimensionless force–displacement relations:

$$\begin{aligned} \bar{Q} &= \frac{H}{R} \left(\frac{d\bar{w}}{d\xi} - \bar{\theta} \right) + 2bH \sin \phi \left[\left(\frac{v}{\xi} - \frac{b}{H} \sin 2\phi \right) \bar{\theta} + \frac{b}{H} \sin 2\phi \frac{d\bar{w}}{d\xi} + \cos^2 \phi \frac{d\bar{\theta}}{d\xi} \right] \\ \bar{M}_r &= -H^2 \cos \phi \left[\left(\frac{v}{\xi} - \frac{b}{H} \sin 2\phi \right) \bar{\theta} + \frac{b}{H} \sin 2\phi \frac{d\bar{w}}{d\xi} + \cos^2 \phi \frac{d\bar{\theta}}{d\xi} \right] \\ \bar{M}_c &= -H^2 \sec \phi \left[\left(\frac{1}{\xi} - v \frac{b}{H} \sin 2\phi \right) \bar{\theta} + v \frac{b}{H} \sin 2\phi \frac{d\bar{w}}{d\xi} + v \cos^2 \phi \frac{d\bar{\theta}}{d\xi} \right] \end{aligned} \quad (8)$$

where ξ is the non-dimensional plate coordinate which is given by $\xi = r/b$ and H is the non-dimensional plate thickness parameter defined as $H = h/h_0$, with h_0 being the plate thickness at $\xi = a/b$ (inner edge). For a linear thickness variation, H may be expressed as

$$H = 1 - \beta(\xi - a/b) \quad a/b \leq \xi \leq 1$$

where β is the plate taper constant determined from the relation

$$\beta = \frac{\bar{h} - 1}{\bar{h}(1 - a/b)}$$

with \bar{h} the known ratio of the inner plate thickness ($\xi = a/b$) to the outer plate thickness ($\xi = 1$). The non-dimensional stress resultants and the displacements are defined as

$$\bar{Q} = \frac{Q}{P_0 b}; \quad \bar{M}_r = \frac{M_r}{P_0 b^2}; \quad \bar{M}_c = \frac{M_c}{P_0 b^2}; \quad \bar{w} = \frac{w D_0}{P_0 b^4}; \quad \text{and} \quad \bar{\theta} = \frac{\theta D_0}{P_0 b^3}$$

where P_0 is any reference quantity having the dimensions of pressure; and D_0 is the plate flexural stiffness at $\xi = a/b$ given as

$$D_0 = \frac{E t h_0^2}{2(1 - \nu^2)}$$

R is defined as

$$R = \frac{D_0}{G h_0 b^2}$$

and will be recognized as a dimensionless measure of the ratio of flexural stiffness to transverse shear stiffness.

The condition of equilibrium of an infinitesimal element of a tapered sandwich plate leads to the following non-dimensional equilibrium equations:

$$\begin{aligned} \frac{\bar{Q}}{\bar{\xi}} + \frac{d\bar{Q}}{d\bar{\xi}} &= -L(\bar{\xi}) \\ \frac{d\bar{M}_r}{d\bar{\xi}} + \frac{\bar{M}_r - M_c}{\bar{\xi}} - \bar{Q} &= 0 \end{aligned} \quad (9)$$

where $L(\bar{\xi}) = q(r)/P_0$. The ordinary differential equations, eqns (8) and (9), together with the boundary conditions at $\bar{\xi} = a/b$ and $\bar{\xi} = 1$, govern \bar{w} , $\bar{\theta}$, \bar{Q} , \bar{M}_r , and \bar{M}_c .

4. POTENTIAL-ENERGY EXPRESSION

An expression can be obtained for the strain energy produced by the face sheet membrane forces and the core shear force by considering the work done by these forces in distorting a sandwich plate differential element. The strain energy of both face sheets is given by

$$SE_{\text{faces}} = \int_0^{2\pi} \int_0^l t(\sigma_s \epsilon_s + \sigma_c \epsilon_c) r \, ds \, dx \quad (10)$$

where l is the length measured along the face sheets. The core strain energy is given by

$$SE_{\text{core}} = \frac{1}{2} \int_0^{2\pi} \int_a^b h \tau_{rz} \gamma_{rz} r \, dr \, dx. \quad (11)$$

Elimination of ds by use of $ds = \sec \phi \, dr$, and the summation of strain energy due to bending, eqn (10), and strain energy due to shear, eqn (11), gives the total plate strain energy expression V_1

$$V_1 = 2\pi \int_a^b \left\{ \text{tr} \sec \phi (\sigma_s \epsilon_s + \sigma_c \epsilon_c) + \frac{r}{2} h \tau_{rz} \gamma_{rz} \right\} dr.$$

Elimination of σ_s , σ_c , and τ_{rz} by means of eqns (5) and (6) gives

$$V_1 = 2\pi \int_a^b \left\{ \text{tr} \sec \phi E^* (\epsilon_s^2 + 2\nu \epsilon_s \epsilon_c + \epsilon_c^2) + \frac{rh}{2} G \gamma_{rz}^2 \right\} dr.$$

The potential energy acquired by the external force, q , in the course of the lateral deflection is given by V_2

$$V_2 = - \iint_A q r \, dr \, d\theta.$$

The total potential energy V of the system comprising the plate and the force q acting on it is the sum of the strain energy V_1 and the potential energy of the external force V_2

$$V = 2\pi \int_a^b \left\{ \text{tr} \sec \phi E^* (\epsilon_s^2 + 2\nu \epsilon_s \epsilon_c + \epsilon_c^2) + \frac{rh}{2} G \gamma_{rz}^2 - qwr \right\} dr.$$

Eliminating ϵ_s , ϵ_c , and γ_{rz} by means of eqns (2)–(4), and nondimensionalizing the resulting expression, yields

$$\bar{V} = \int_{a/b}^1 \left\{ A \left(\frac{d\theta}{d\xi} \right)^2 + (C+K) \left(\frac{d\bar{w}}{d\xi} \right)^2 + B \frac{d\theta}{d\xi} \frac{d\bar{w}}{d\xi} + (D-B)\theta \frac{d\theta}{d\xi} + (E-2C-2K)\theta \frac{d\bar{w}}{d\xi} + (C-E+F+K)\theta^2 - 2L\xi\bar{w} \right\} d\xi \quad (12)$$

where

$$\begin{aligned} A &= H^2 \xi \cos^3 \phi \\ B &= 2H\bar{b}\xi \sin 2\phi \cos \phi \\ C &= 2\bar{b}^2 \xi \sin \phi \sin 2\phi \\ D &= 2\nu H^2 \cos \phi \\ E &= 4\nu\bar{b}H \sin \phi \\ F &= \frac{H^2}{\xi} \sec \phi, \quad K = \frac{\xi H}{R}, \quad \bar{V} = \frac{D_0}{P_0^2 \bar{b}^6 \pi} V. \end{aligned} \quad (13)$$

The above expression applies when the boundary reactions do no work and, therefore, acquire no potential energy in the course of the plate's deflection. Equation (12) is, therefore, applicable when the edges of the plate are free, simply supported, or clamped.

The mutual consistency of the differential equations and the energy expressions is confirmed by means of the calculus of variations, and is presented in the Appendix.

5. ILLUSTRATIVE APPLICATION

In this section, we present the solution for an annular sandwich plate with linear thickness variation which is clamped at the inner edge and is free at the outer edge. b/h_0 is taken to be 7 and $b/a = 4$. Poisson's ratio of the face sheets is assumed to be 0.3. The loading consists of running uniform vertical load $q = P_0$ per unit middle surface area. The solution to eqns (8) and (9) is obtained by the finite difference technique with the boundary conditions replacing the equilibrium equations at the boundary grid points.

Figure 2 shows the non-dimensional deflection curve as a function of ξ for different values of R . The thickness at the inner edge is twice that of the outer edge, $\bar{h} = 2$, where \bar{h} is defined as the ratio of the inner edge thickness to the outer edge thickness. $R = 0.4$

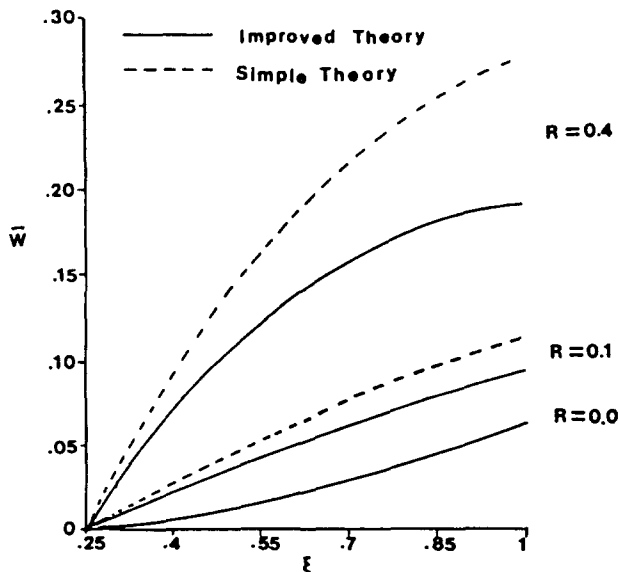

Fig. 2. Non-dimensional deflection as a function of ξ with $\bar{h} = 2$.

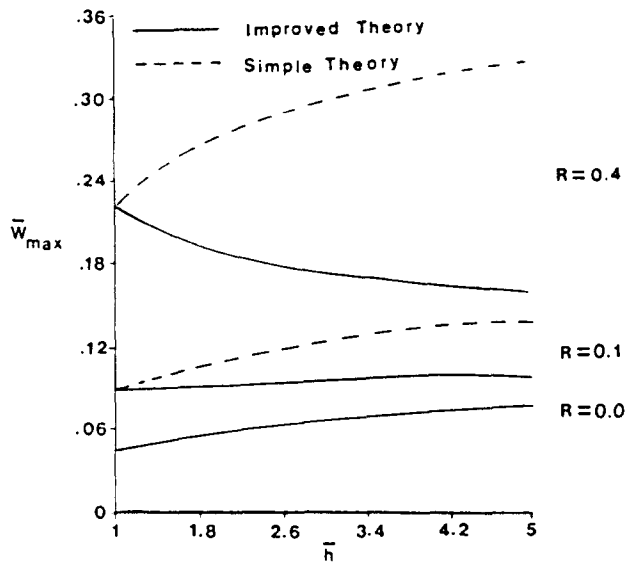

Fig. 3. Maximum non-dimensional deflection as a function of \bar{h} .

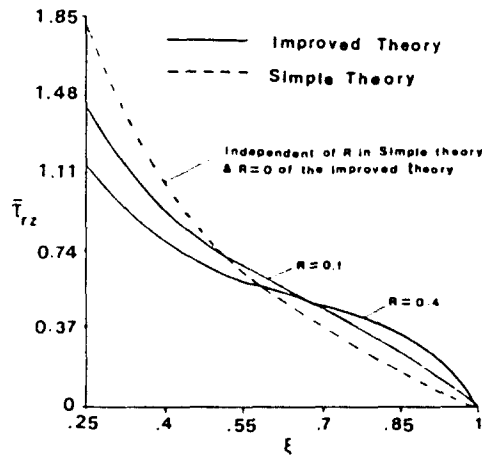

Fig. 4. Non-dimensional core shear stress as a function of ξ .

corresponds, for example, to a core shear modulus of 196 MPa in a plate with 0.25 cm thick faces, $E = 200$ GPa, $h_0 = 7.14$ cm, $a = 12.5$ cm, and $b = 50$ cm. This figure contains two sets of results: (a) results obtained by present ("Improved") theory, (b) results based on the locally-constant-thickness sandwich plate theory (which we label "Simple" theory for the lack of a better word). It is seen that the two theories agree very closely, as they should, when $R = 0$ (core not deformable in transverse shear), but can differ appreciably when $R \neq 0$. Figure 3 shows plate maximum deflection as a function of \bar{h} . It will be noted that the low R and high R curves have opposite trends as \bar{h} increased from 1 to 5. That is because increasing \bar{h} (i.e. increasing the thickness taper) has two opposite effects: by reducing the thickness, the face sheet stresses are increased, thereby increasing the bending deflection. At the same time, the participation of the face sheets in resisting transverse shear is increased, which reduces the core shear stresses and, therefore, the deflection due to shear. When the core transverse shear stiffness is low ($R = 0.4$), the second effect predominates, while when the core transverse shear stiffness is high ($R = 0$ or 0.1), the first effect predominates. Figure 4 shows the non-dimensional core shear stress, $\bar{\tau}_{rz} = \tau_{rz}h_0/P_0h$, as a function of ξ for different values of \bar{h} .

We have no experimental results to compare with the above theoretical results. However, tests on variable thickness sandwich beams, reported by Lu[6], tend to confirm the main premises of the present analysis. A comparison has been made in Ref. [5] between the experimental results of Ref. [6] and the theoretical predictions of the improved and the

simple theory. It is seen that the improved theory is in much better agreement with experiment than is the simple theory, especially for the higher values of taper constant β .

6. CONCLUSION

A small deflection theory is presented for the stresses and deformations in variable thickness elastic annular sandwich plates that are symmetric about a middle surface. In this analysis, the face sheets are treated as membranes, the core is assumed to be inextensible in the thickness direction, and to be deformable in transverse shear. The theory takes into account the contribution of the face sheet membrane forces (by virtue of their slopes) to the transverse shear.

Numerical comparisons showed that an alternate theory, based on the assumptions that the constant-thickness constitutive equations are valid locally, can be appreciably in error, although such a theory is quite acceptable for homogeneous plates of variable thickness.

REFERENCES

1. S. Timoshenko and S. Woinowsky-Krieger, *Theory of Plates and Shells*, 2nd Edn. McGraw-Hill, New York (1959).
2. S. N. Huang and D. W. Alspaugh, Minimum weight sandwich beam design. *AIAA J.* **12**, 1617-1618 (1974).
3. C. Libove and S. B. Batdorf, A general small deflection theory for flat sandwich plates. NACA Report 899 (1948).
4. N. Paydar, Stress analysis of variable thickness sandwich plates of rectangular planform. Ph.D. Dissertation, Syracuse University, Syracuse, New York (1985).
5. N. Paydar and C. Libove, Stress analysis of sandwich plates with unidirectional thickness variation. *J. Appl. Mech.* **53**, 609-613 (1986).
6. C. Lu, Static deflection and harmonic vibration tests of variable thickness sandwich beams, Master's Thesis, Syracuse University, Syracuse, New York (1984).

APPENDIX: DERIVATION OF EQUILIBRIUM EQUATIONS AND GENERAL BOUNDARY CONDITIONS BY A VARIATIONAL METHOD

The conditions that must be satisfied if the total potential energy V of the system is to be a minimum are considered here. By the calculus of variations, minimization of V requires the vanishing of the first variation δV . The first variation can be evaluated from eqn (12) as

$$\delta \mathcal{P} = \int_{a,b} \left\{ \left[2A \frac{d\bar{\theta}}{d\bar{\xi}} + B \frac{d\bar{w}}{d\bar{\xi}} + (D-B)\bar{\theta} \right] \frac{d}{d\bar{\xi}} (\delta\bar{\theta}) + \left[B \frac{d\bar{\theta}}{d\bar{\xi}} + 2(C+K) \frac{d\bar{w}}{d\bar{\xi}} + (E-2C-2K)\bar{\theta} \right] \frac{d}{d\bar{\xi}} (\delta\bar{w}) \right. \\ \left. + \left[(D-B) \frac{d\bar{\theta}}{d\bar{\xi}} + (E-2C-2K) \frac{d\bar{w}}{d\bar{\xi}} + 2(C-E+F+K)\bar{\theta} \right] \delta\bar{\theta} - 2L\bar{\xi} \delta\bar{w} \right\} d\bar{\xi}. \quad (A1)$$

Those terms in the above expression that contain derivatives of $\delta\bar{w}$ and $\delta\bar{\theta}$ can be integrated by parts so as to reduce the order of the derivatives

$$\delta \mathcal{P} = \int_{a,b} \left\{ \left\{ -\frac{d}{d\bar{\xi}} \left[2A \frac{d\bar{\theta}}{d\bar{\xi}} + B \frac{d\bar{w}}{d\bar{\xi}} + (D-B)\bar{\theta} \right] + (D-B) \frac{d\bar{\theta}}{d\bar{\xi}} + (E-2C-2K) \frac{d\bar{w}}{d\bar{\xi}} + 2(C-E+F+K)\bar{\theta} \right\} \delta\bar{\theta} \right\} d\bar{\xi} \\ + \int_{a,b} \left\{ \left\{ -\frac{d}{d\bar{\xi}} \left[B \frac{d\bar{\theta}}{d\bar{\xi}} + 2(C+K) \frac{d\bar{w}}{d\bar{\xi}} + (E-2C-2K)\bar{\theta} \right] - 2L\bar{\xi} \right\} \delta\bar{w} \right\} d\bar{\xi} \\ + \left[2A \frac{d\bar{\theta}}{d\bar{\xi}} + B \frac{d\bar{w}}{d\bar{\xi}} + (D-B)\bar{\theta} \right] \delta\bar{\theta} \Big|_{a,b} + \left[B \frac{d\bar{\theta}}{d\bar{\xi}} + 2(C+K) \frac{d\bar{w}}{d\bar{\xi}} + (E-2C-2K)\bar{\theta} \right] \delta\bar{w} \Big|_{a,b}.$$

In order for $\delta \mathcal{P}$ as given by the above expression to be zero for all possible values of $\delta\bar{w}$ and $\delta\bar{\theta}$, the various integrals must individually be zero. The following differential equations result from equating the line integrals to zero:

$$\frac{d}{d\bar{\xi}} \left\{ -H^2 \cos \phi \left[\left(\frac{v}{\bar{\xi}} - \frac{b}{H} \sin 2\phi \right) \bar{\theta} + \frac{b}{H} \sin 2\phi \frac{d\bar{w}}{d\bar{\xi}} + \cos^2 \phi \frac{d\bar{\theta}}{d\bar{\xi}} \right] \right\} + \left\{ -H^2 \cos \phi \left[\left(\frac{v}{\bar{\xi}} - \frac{b}{H} \sin 2\phi \right) \bar{\theta} \right. \right. \\ \left. \left. + \frac{b}{H} \sin 2\phi \frac{d\bar{w}}{d\bar{\xi}} + \cos^2 \phi \frac{d\bar{\theta}}{d\bar{\xi}} \right] \right\} + \frac{1}{\bar{\xi}} \left\{ -H^2 \cos \phi \left[\left(\frac{v}{\bar{\xi}} - \frac{b}{H} \sin 2\phi \right) \bar{\theta} + \frac{b}{H} \sin 2\phi \frac{d\bar{w}}{d\bar{\xi}} + \cos^2 \phi \frac{d\bar{\theta}}{d\bar{\xi}} \right] \right\}$$

$$\begin{aligned}
 &+ H^2 \sec \phi \left[\left(\frac{1}{\xi} - v \frac{b}{H} \sin 2\phi \right) \bar{\theta} + v \frac{b}{H} \sin 2\phi \frac{d\bar{w}}{d\xi} + v \cos^2 \phi \frac{d\bar{\theta}}{d\xi} \right] - \left\{ \frac{H}{R} \left(\frac{d\bar{w}}{d\xi} - \bar{\theta} \right) \right. \\
 &\left. + 2bH \sin \phi \left[\left(\frac{v}{\xi} - \frac{b}{H} \sin 2\phi \right) \bar{\theta} + \frac{b}{H} \sin 2\phi \frac{d\bar{w}}{d\xi} + \cos^2 \phi \frac{d\bar{\theta}}{d\xi} \right] \right\} = 0
 \end{aligned} \tag{A2}$$

$$\begin{aligned}
 \frac{1}{\xi} \left\{ \frac{H}{R} \left(\frac{d\bar{w}}{d\xi} - \bar{\theta} \right) + 2bH \sin \phi \left[\left(\frac{v}{\xi} - \frac{b}{H} \sin 2\phi \right) \bar{\theta} + \frac{b}{H} \sin 2\phi \frac{d\bar{w}}{d\xi} + \cos^2 \phi \frac{d\bar{\theta}}{d\xi} \right] \right\} + \frac{d}{d\xi} \left\{ \frac{H}{R} \left(\frac{d\bar{w}}{d\xi} - \bar{\theta} \right) \right. \\
 \left. + 2bH \sin \phi \left[\left(\frac{v}{\xi} - \frac{b}{H} \sin 2\phi \right) \bar{\theta} + \frac{b}{H} \sin 2\phi \frac{d\bar{w}}{d\xi} + \cos^2 \phi \frac{d\bar{\theta}}{d\xi} \right] \right\} = -L
 \end{aligned} \tag{A3}$$

$$-H^2 \cos \phi \left[\left(\frac{v}{\xi} - \frac{b}{H} \sin 2\phi \right) \bar{\theta} + \frac{b}{H} \sin 2\phi \frac{d\bar{w}}{d\xi} + \cos^2 \phi \frac{d\bar{\theta}}{d\xi} \right] \delta \bar{\theta} \Big|_{\mu, h} = 0 \tag{A4}$$

$$\left\{ \frac{H}{R} \left(\frac{d\bar{w}}{d\xi} - \bar{\theta} \right) + 2bH \sin \phi \left[\left(\frac{v}{\xi} - \frac{b}{H} \sin 2\phi \right) \bar{\theta} + \frac{b}{H} \sin 2\phi \frac{d\bar{w}}{d\xi} + \cos^2 \phi \frac{d\bar{\theta}}{d\xi} \right] \right\} \delta \bar{w} \Big|_{\mu, h} = 0. \tag{A5}$$

By virtue of eqns (8), the above expressions can be rewritten as

$$\frac{d\bar{M}_r}{d\xi} + \frac{\bar{M}_r - \bar{M}_c}{\xi} - \bar{Q} = 0 \tag{A6}$$

$$\frac{\bar{Q}}{\xi} + \frac{d\bar{Q}}{d\xi} = -L. \tag{A7}$$

$$\bar{M}_r = 0 \quad \text{or} \quad \delta \bar{\theta} = 0 \tag{A8}$$

$$\bar{Q} = 0 \quad \text{or} \quad \delta \bar{w} = 0. \tag{A9}$$

Equations (A6) and (A7) are the differential equations that must be satisfied if the potential energy is to be a minimum. They will be recognized as the equations of equilibrium, eqns (9). Equations (A8) and (A9) are the boundary conditions that must be satisfied if the potential energy is to be a minimum.